

THIS DRAWING IS UNPUBLISHED. RELEASED FOR PUBLICATION 20
 © COPYRIGHT 20 BY TYCO ELECTRONICS CORPORATION. ALL RIGHTS RESERVED.

LOC	DIST	REVISIONS					
CE	00	P	LTR	DESCRIPTION	DATE	DWN	APVD
			W	REVISE PER ECR-07-026329	06NOV2007	BB	DK
			W1	ENGINEERING CHANGES	19DEC2007	BB	DK
			W2	ENGINEERING CHANGES	07JAN2008	BB	DK

⚠ MANUFACTURERS' INSTRUCTION SHEETS

⚠ OPTIONAL SHOULDER STRAP

3. INSTRUCTION SHEETS 408-4020, 408-8925, 408-10103, 408-4555, 408-4457, AND 408-4471 EXPLAIN THE LightCrimp Plus LC TERMINATION TECHNIQUE AND ARE AVAILABLE FOR DOWNLOAD AT www.catalog.tycoelectronics.com.

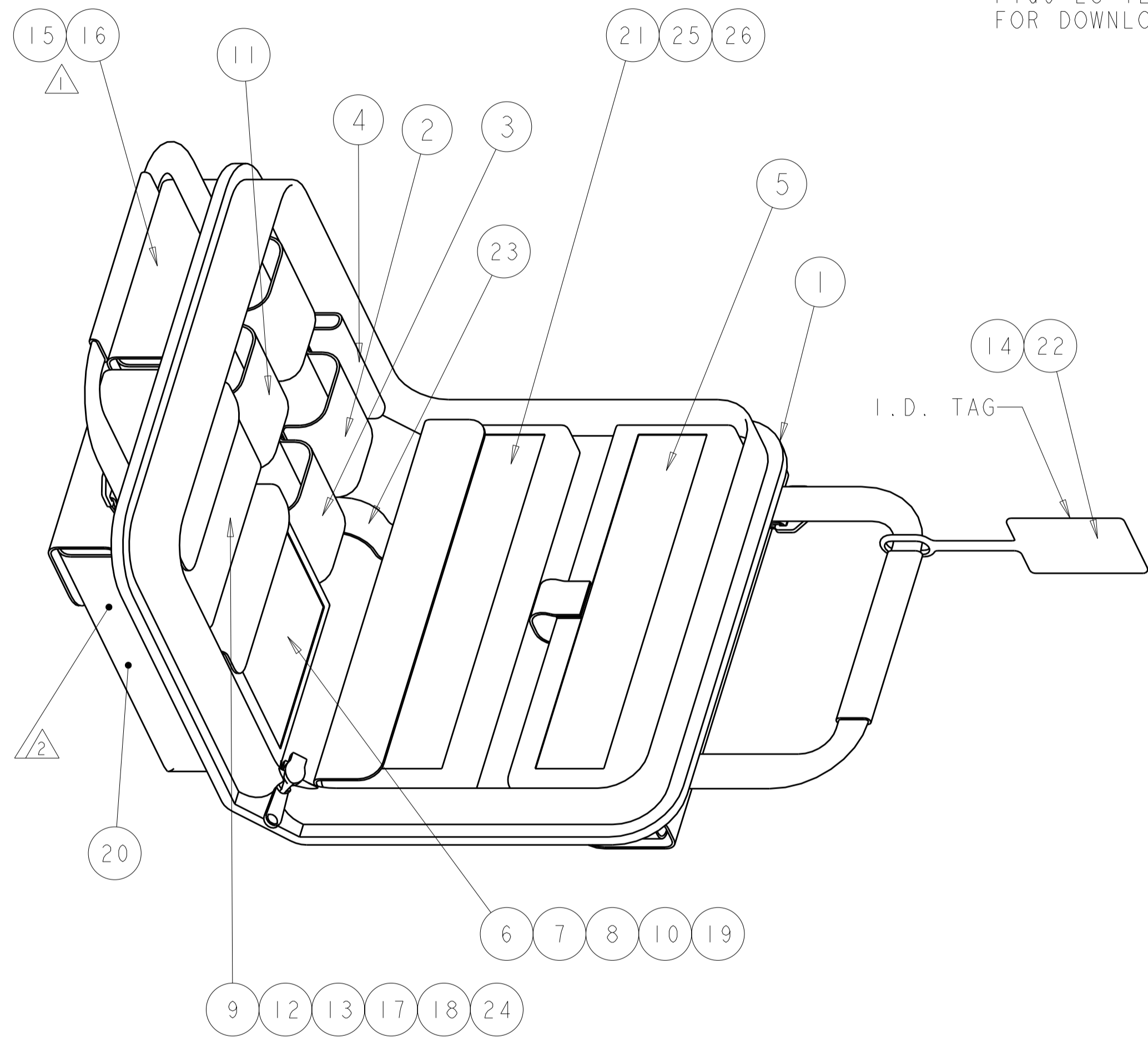

OBSOLETE
OBSOLETE
SUPERCEDED BY:
1278118-4

QTY	UNIT	DESCRIPTION	PART NUMBER	ITEM			
1	-	MICROSCOPE ADAPTER, 1.25mm	1754765-1	26			
1	-	MICROSCOPE ADAPTER, MT-RJ	1754768-1	25			
1	1	CABLE CLAMP	1278625-1	24			
1	1	SCISSORS	501014-1	23			
1	-	LABEL, TERMINATION KIT	1374331-2	22			
1	-	200x MICROSCOPE	1754767-1	21			
1	1	FIBER CLEAVER, SLIDE CUTTER	1871696-1	20			
1	1	BUFFER HOLDER, LIGHTCRIMP PLASTIC	1754138-1	19			
1	1	LIGHTCRIMP PLUS DIESET, LC	1754136-1	18			
1	1	BALL END HEX KEY (5)	1457999-1	17			
1	1	CD-ROM, MT-RJ TERM TRAINING	1435138-1	16			
1	1	CD - ROM, TERMINATION TRAINING	1374503-1	15			
-	1	LABEL, TERMINATION KIT	1374331-1	14			
1	1	STRIP TEMPLATE, MT-RJ	1278598-1	13			
2	2	ACTUATION KEY, MT-RJ	1278576-1	12			
1	1	MICRO-STRIPPER, MT-RJ	492109-2	11			
1	1	OPTIMATE CABLE STRIPPER	501198-1	10			
14	14	ALCOHOL FIBER WIPE	501857-2	9			
1	1	CABLE/BUFFER HOLDER, LightCrimp Plus AMP SC	1278023-1	8			
1	1	CABLE/BUFFER HOLDER, LightCrimp Plus ST-STYLE	492703-1	7			
1	1	LightCrimp Plus DIESET, ST-STYLE	492622-1	6			
1	1	LightCrimp Plus PROCRIMPER W/DIESET, AMP SC	492782-1	5			
2	2	WRENCH, 1/4 OPEN END	1278422-1	4			
1	1	KEVLAR SHEARS	1278637-1	3			
1	1	STRIP TOOL, FIBER, COMBINATION	1754708-1	2			
1	1	PREMIUM SOFTCASE	1278540-1	1			
-5	-4	-3	-2	-1	DESCRIPTION	PART NUMBER	ITEM

THIS DRAWING IS A CONTROLLED DOCUMENT FOR TYCO ELECTRONICS CORPORATION. IT IS SUBJECT TO CHANGE AND THE CONTROLLING ENGINEERING ORGANIZATION SHOULD BE CONTACTED FOR THE LATEST REVISION.

DWN: T. ALEXANDER 15NOV2000
 CHK: M. HAMONKO 15NOV2000
 APVD: S. BUCHTER 15NOV2000

Tyco Electronics
 Harrisburg, PA 17105-3608

NAME: TERMINATION KIT, COMBINATION, LightCrimp Plus AND MT_RJ JACK

SIZE: A2 CAGE CODE: 00779 DRAWING NO: 1278118 RESTRICTED TO: -

MATERIAL: - DIMENSIONS: INCHES TOLERANCES UNLESS OTHERWISE SPECIFIED: 0 PLC ±, 1 PLC ±0.1, 2 PLC ±0.02, 3 PLC ±0.005, 4 PLC ±0.0005, ANGLES ±, FINISH -

PRODUCT SPEC: - APPLICATION SPEC: - WEIGHT: -

CUSTOMER DRAWING SCALE: 1:2 SHEET 1 OF 1 REV: W2